

STULZ

CLIMATE. CUSTOMIZED.



CyberCool WaterTec

Forward-thinking, environmentally friendly and efficient.
The new water-cooled chiller by STULZ.

STULZ air conditioning systems for mission-critical applications – around the globe



For 40 years we have been one of the world's leading manufacturers of air conditioning solutions for mission-critical applications. For our customers, we develop and produce air conditioning systems and chillers, plan individual air conditioning solutions, implement the systems and keep them up and running with our own service department.

Our headquarters are in Hamburg. With 20 subsidiaries, 10 production sites, and sales and service partners in over 140 countries, we make sure we are close to our customers wherever they are in the world.



Technical peak performance from Germany

It is the combination of decades of experience and a continuous innovative spirit that makes STULZ unique. From engineers to customer advisers, we collaborate in close-knit teams to develop and continually optimize our air conditioning and chilled water systems throughout all stages of development. So it should come as no surprise that our systems are extremely reliable and durable, setting the benchmark for energy efficiency around the globe.



High quality service worldwide close to you

Our trained and experienced sales and service partners are located in over 140 countries. The resulting proximity to our customers allows fast response times. In addition, regular training courses and an active exchange of information ensure high quality and an extensive knowledge of all our products. This way, you can be sure your products are in the best hands and get the right maintenance - all over the world.

Use the technology of the future, today

Chillers are the ideal air conditioning solutions for mission-critical applications. The biggest hurdles are the comparatively high investment and refrigeration costs, as well as installing and replacing the units. STULZ have been dedicating themselves to addressing these challenges and offer a solution that already meets the requirements of ErP 2021.

The CyberCool WaterTec is a water-cooled chiller that combines all the relevant factors: the design is compact and maintenance friendly, the Turbocor technology is optimized for partial loads, and, in a forward-thinking manner, refrigerant quantities are minimized with the simultaneous use of a refrigerant that has a very low global warming potential.

CyberCool WaterTec

- Water-cooled chiller
- Cooling capacity from 350 to 1,400 kW
- Available in 5 different sizes
- Partial load-optimized Turbocor technology
- ErP 2021 ready

+ Advantages at a glance

- Refrigerant quantities are significantly reduced, thanks to innovative spray evaporator technology
- Uses refrigerant R1234ze, which has a very low global warming potential
- Contains partial load optimized Turbocor technology, for increased efficiency
- Easy to integrate and maintain
- Operates with minimal noise and vibration
- Operating costs are minimal through the Free Cooling module (option)



Optimal cooling generation for mission-critical applications

Whether high-performance computing, data centers, industrial facilities or entire buildings, CyberCool WaterTec is well-suited for all of your mission-critical applications. The installation process is straightforward, thanks to its compact design, even when installation occurs in the vicinity of consumers. Devising bespoke solutions and adding extra features are commonplace for STULZ, and this ensures that we can meet our customers' every need and reduce any safety risk, however small.



+ Advantages for cooling data centers

- High-performance and reliable cooling for data centers of any size
- Partial load optimization and Free Cooling module (option) ensure energy efficiency all-year round
- Automatic transfer switch (option) and quick-start function guarantee maximum operational reliability
- Integration and maintenance are hassle-free thanks to its compact design and easy dismantlement

+ Advantages for process and industrial cooling

- High-performance and reliable cooling for small and large-scale industrial facilities
- Easy integration for both existing liquid cooling systems and new ones
- Ideal for mission-critical applications that require high-level efficiency
- Broad operating range with chilled water outlet temperatures of 1 °C to 19 °C

+ Advantages for building cooling

- High-performance and reliable cooling of entire buildings (including large buildings such as hospitals)
- Operates with minimal noise and vibration (low emissions both in- and outward)
- Environmental footprint is very good, as a result of high efficiency and environment-friendly refrigerant
- Adapts particularly rapidly to variable loads



Fast and trouble-free: integration and maintenance

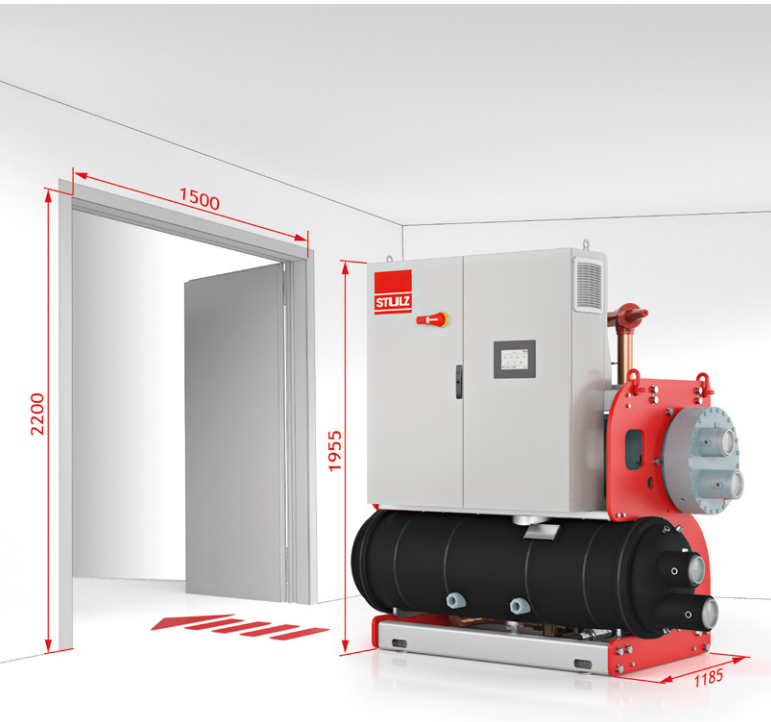

Compact design

Installing and replacing chillers is usually associated with a lot of hassle and high costs. In order to relieve the customer when integrating the new unit, STULZ have attached great importance to the compact design of the CyberCool WaterTec. As a result, we are often able to integrate the unit in a pre-assembled state.

Easy to dismantle

The entire design of the CyberCool WaterTec makes life easier for the user – and not just because it takes up minimal space. Its modular design makes the unit very easy to dismantle into separate components, if required. Even the frame, which must adhere to the highest stability requirements, can be easily dismantled. As a result, the CyberCool WaterTec does not require any effort when being installed, even in difficult conditions, and is always easy to service. And if there is the need to fit it to the wall, the switch gear cabinet is equipped with hooks at the back.

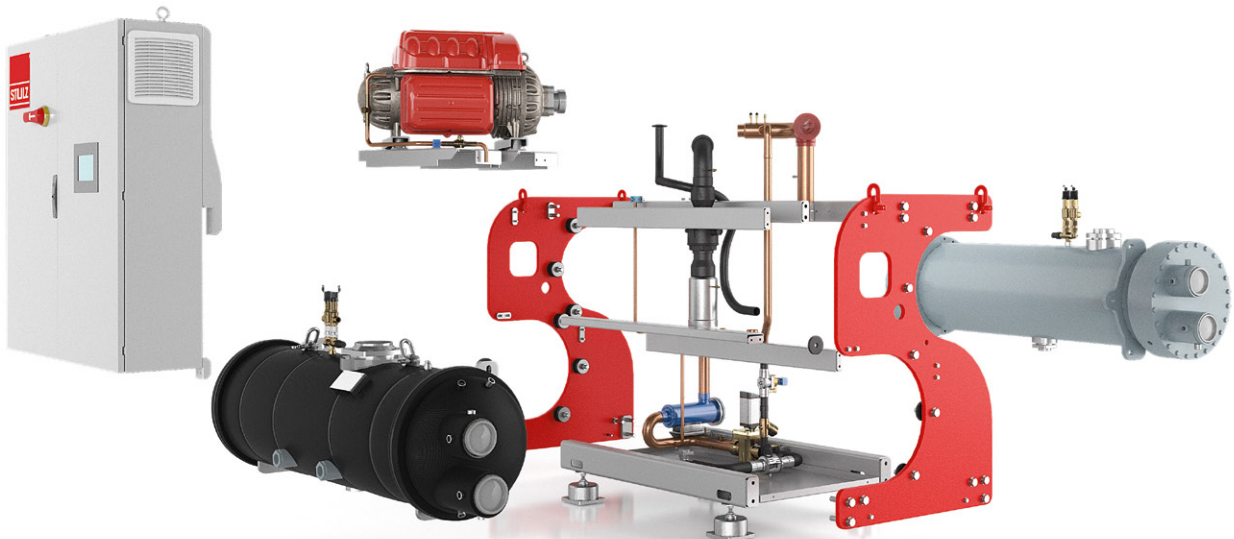

Intelligent switching operation and control

Here at STULZ we develop software and hardware in an integrated process, whereby engineers and software developers work hand-in-hand to find the best solution.

In this way, we can develop digital control systems that reflect the reliability and efficiency that customers expect of our system controls, and for which STULZ has stood for decades.

The result: STULZ controllers are highly reliable and are easy and intuitive to operate. They coordinate the components of the CyberCool WaterTec completely automatically and enable the unit to be connected easily to all usual building management systems. The operating system is generally very flexible and, by request, it can be extended with several parameters and functions.

The SEC.blue controller is very easy to handle for both operators and service technicians. Thanks to its multiple display graphics, it offers an intuitive user experience.

- Up-to-date hardware, state-of-the-art software
- The software is adapted to each project and ensures a high level of connectivity and flexibility
- Intelligent switch operation and control of partial load mode
- Several chillers can be operated in parallel across machines
- Option: Control of external components, such as pumps, valves, and dry cooler

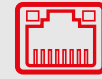

Ethernet



ModBus RTU,
TCP-IP



Micro SD



Programmable



Color touchscreen

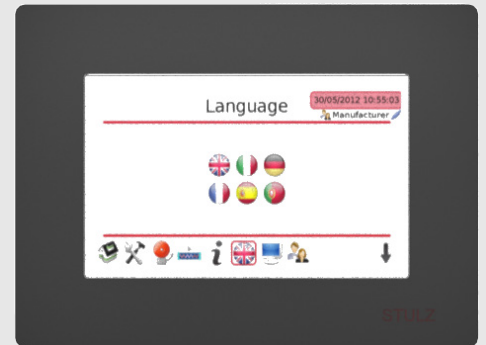

7" touchscreen display



Web server

0 % oil, 70 % less refrigerant, 100 % cooling capacity

The shortage of refrigerants makes the type and filling quantity of refrigerants an increasingly important cost factor. STULZ is already reacting to these issues with future-proof solutions. The components of the CyberCool WaterTec work together in such an efficient manner that mission-critical refrigeration systems can be operated efficiently, economically and with respect for the environment – without any safety or reliability restrictions.

Partial load mode improves efficiency

Depending on the size of the unit, the CyberCool WaterTec is equipped with between 1-4 Turbocor compressors, for partial load-optimized operation. The compressors run with magnetic bearings, which enables the system to operate completely oil-free. The efficient technology works without any friction losses and reduces operating costs.

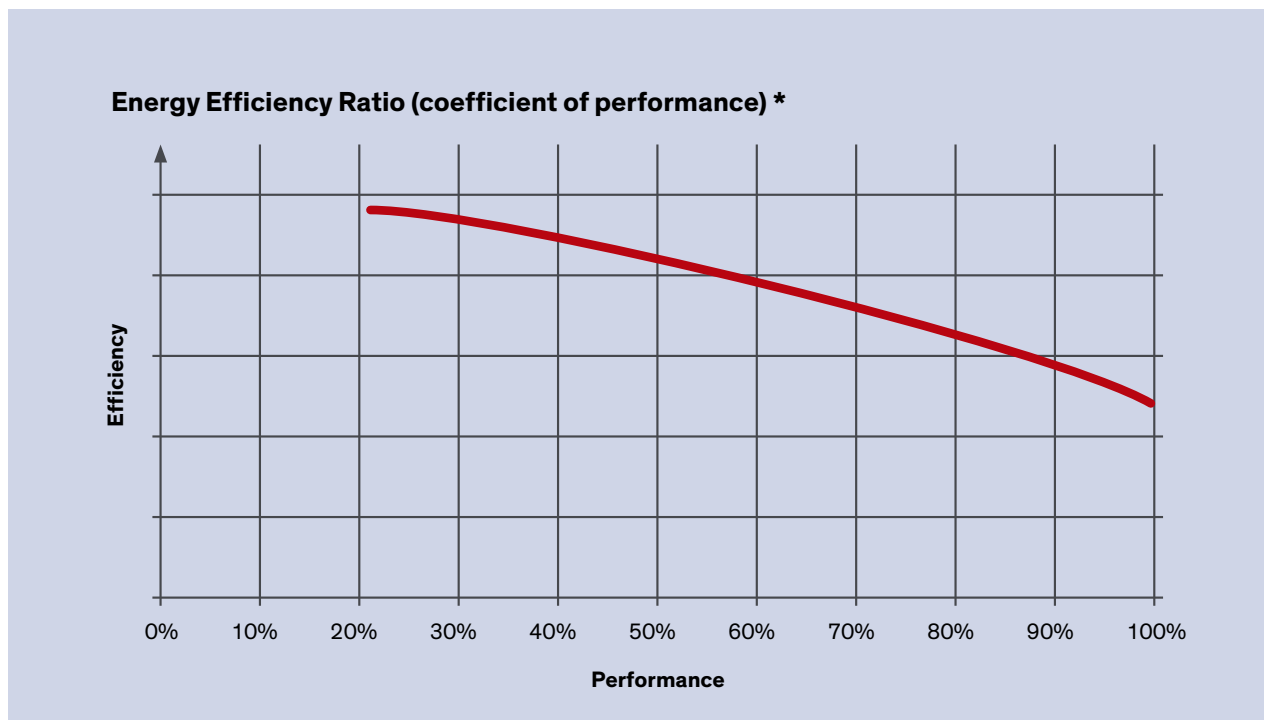

* TSI 03501 WTTA

Refrigerant R1234ze has very low global warming potential

The CyberCool WaterTec runs on the environment-friendly refrigerant R1234ze as standard. The HFO refrigerant has a very low global warming potential and is well-suited as a future-proof and efficient alternative to traditional HFC-based refrigerants. This is STULZ's sustainable solution to the refrigerant shortage which was triggered by the (EU) regulation number 517/2014.



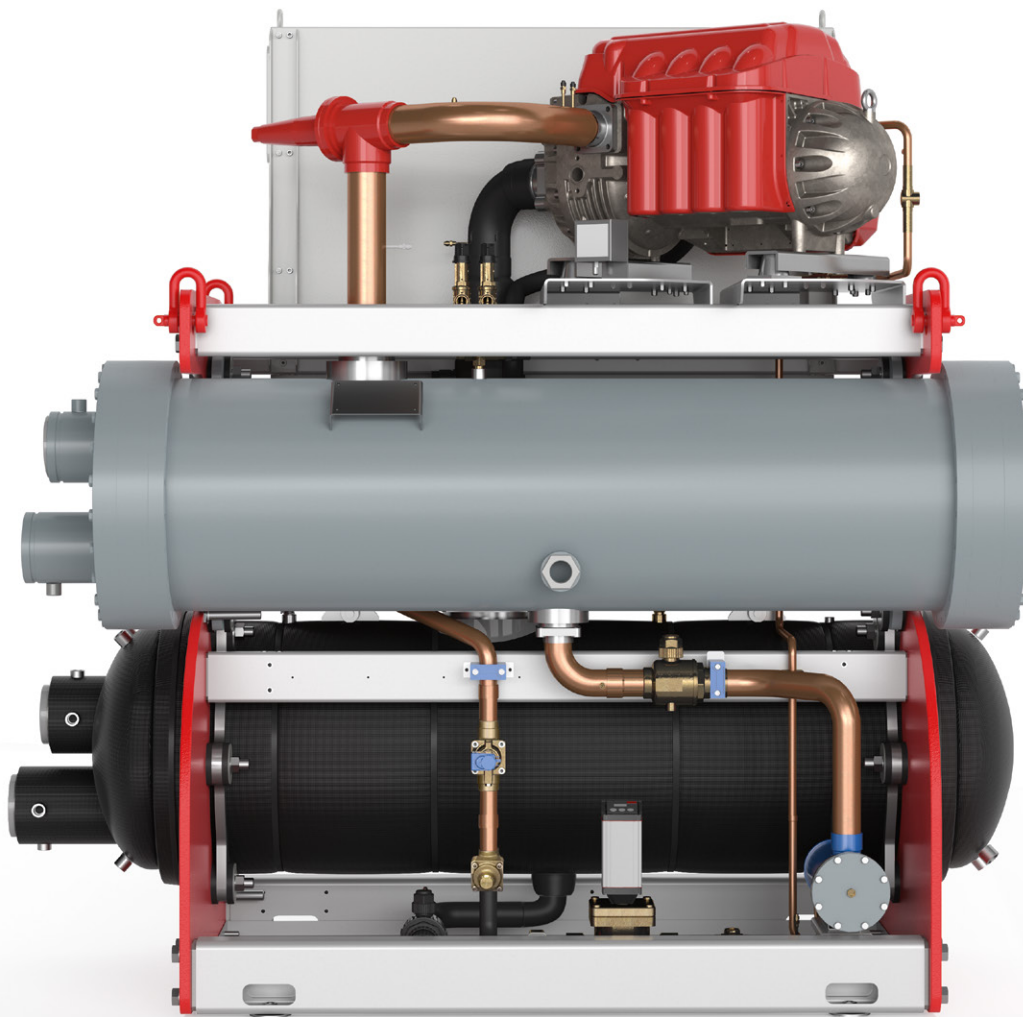

Up to 70 % less refrigerant

The CyberCool WaterTec is equipped as standard with the innovative spray evaporator technology. It enables the unit to operate with up to 70 % less refrigerant compared to flooded evaporators with the same level of efficiency. This not only helps the environment, but also makes a positive and noticeable difference to procurement costs.

The use of the refrigerant R1234ze and an innovative spray evaporator ensure environmentally friendly and economical operation. CyberCool WaterTec already meets the requirements of ErP 2021.

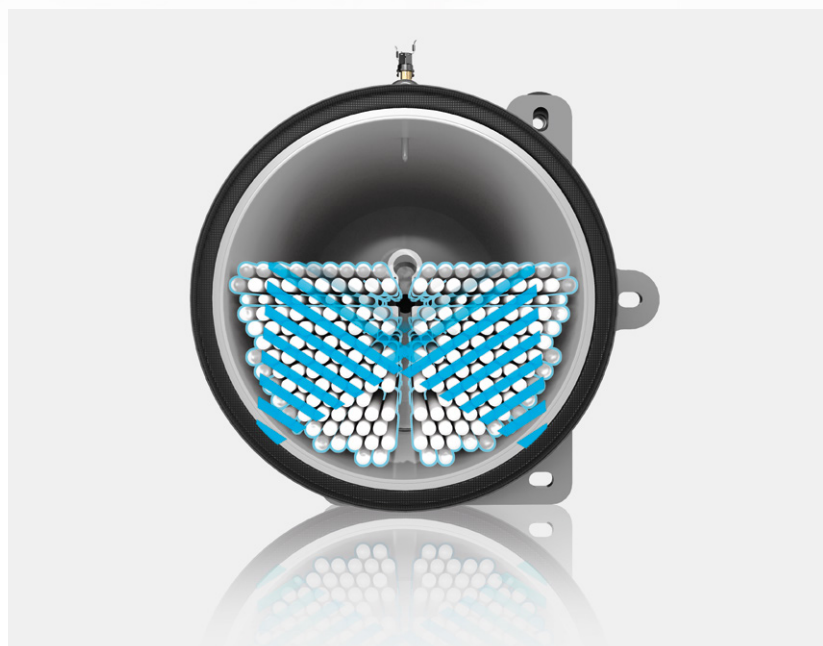

Three operation modes for maximum efficiency

Depending on the outdoor temperature, the most efficient mode is selected automatically and reliably throughout the year, whatever the local temperature profile.

Compressor mode (DX)

At high outdoor temperatures, the entire cooling capacity is achieved using the compressor. The CyberCool WaterTec works very efficiently, even in this mode, by using perfectly-matched components.

Mixed mode

At moderate temperatures, the CyberCool WaterTec runs in energy-efficient mixed mode – a combination of Free Cooling and significantly reduced compressor cooling.

Free Cooling mode (FC)

At low outdoor temperatures, Free Cooling delivers the greatest potential savings. In this case, only outside air is used for cooling and compressor cooling is switched off completely.

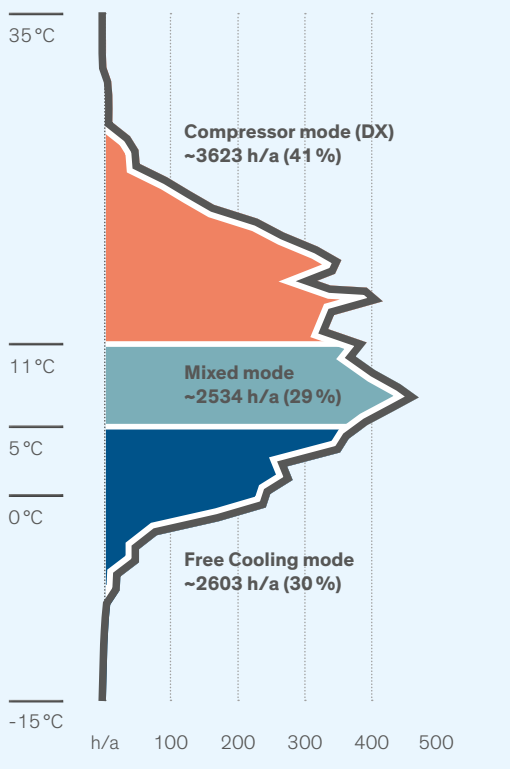

Location: Hamburg
Model: TSI 03501 WTTA
Chilled water temperature: 18/12 °C
30% Ethylene glycol

Option: Free Cooling module

Free Cooling is an intelligent solution for minimizing the energy-intensive compressor mode and for cutting operating costs significantly. With the Free Cooling module, the CyberCool WaterTec uses the outdoor temperature, which offers the greatest potential savings, especially in cold and temperate local climates.

The Free Cooling module is easy to integrate and to connect to the piping by means of a Victaulic coupling. The switch gear cabinet of the unit – which includes the SEC.blue controller – ensures optimum switching operation and control, as well as seamless communication with the CyberCool WaterTec.

Measurements (LxWxH):

2,200 × 1,100 × 2,200 mm

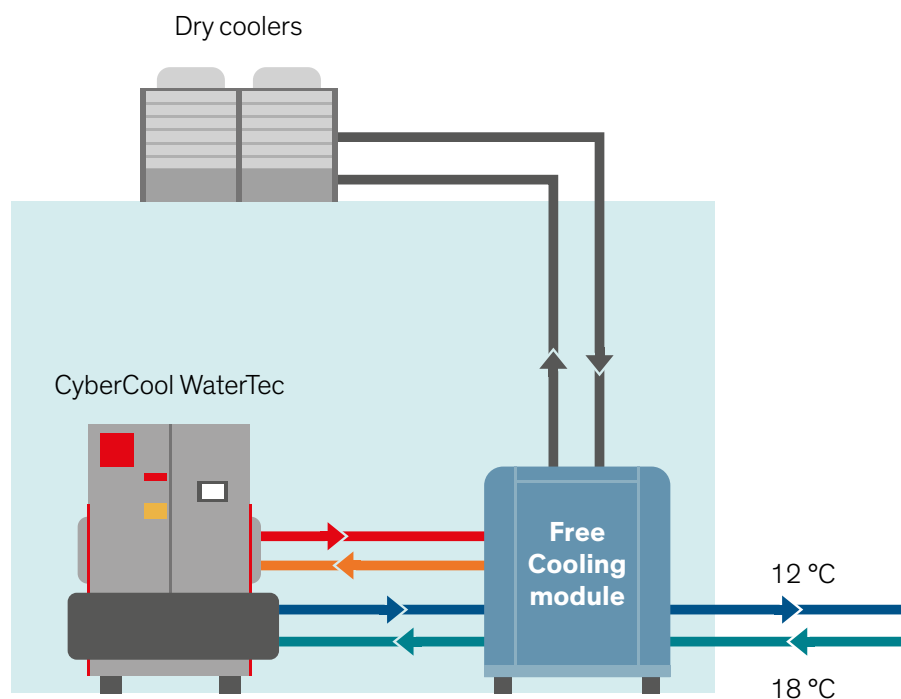

Option: Second power source for the greatest possible reliability

One of the key requirements for mission-critical and sensitive applications is uninterrupted cooling – in the event of a power outage, for example. To guarantee stable cooling capacity in spite of this, STULZ provides the option of an **automatic transfer switch** fitted directly in the switch gear cabinet. If the primary power supply fails, this is detected automatically and the system defaults to a second power source within a minimum of **180 ms**.

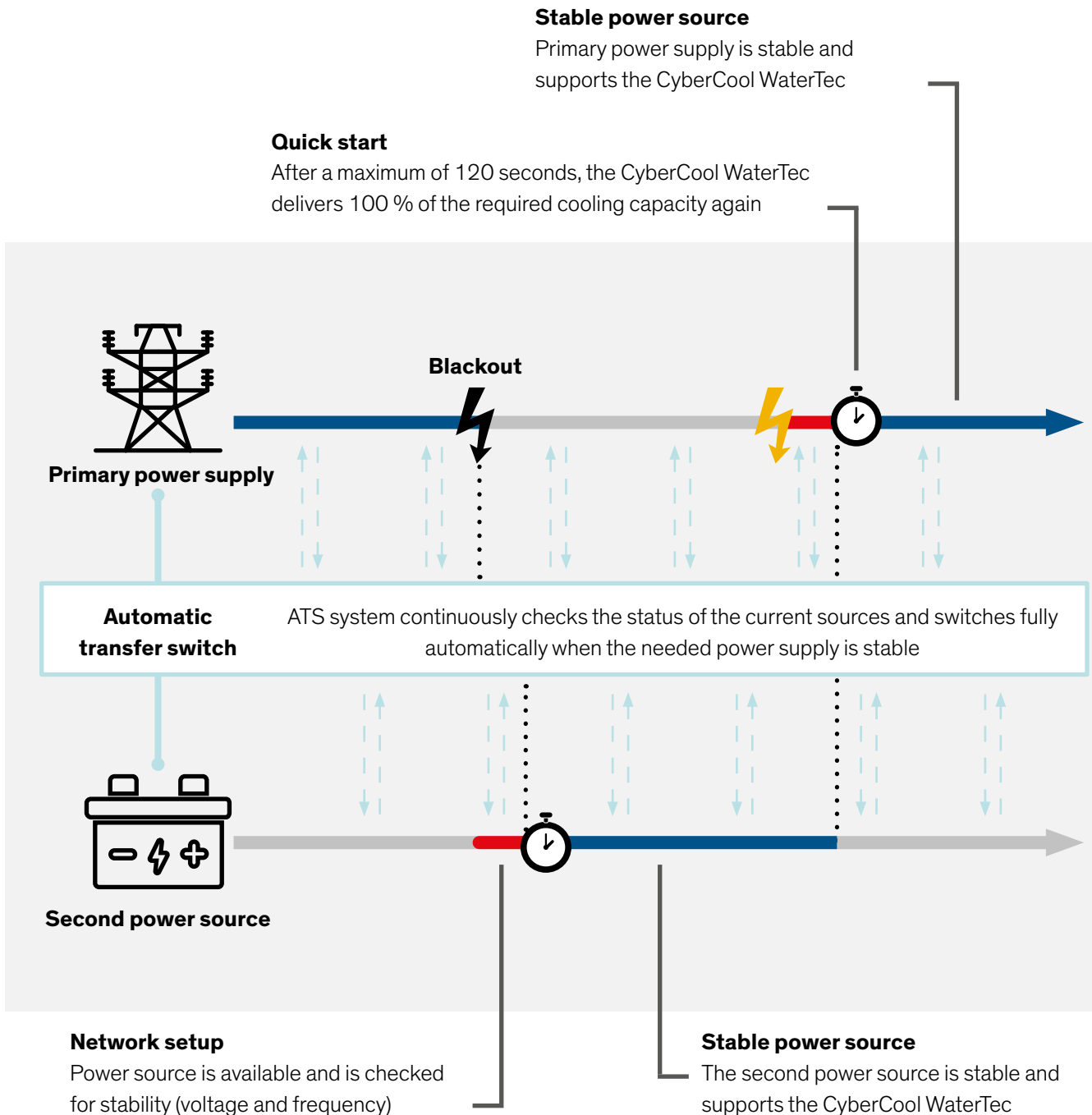

Operational reliability

**The CyberCool WaterTec offers maximum operational reliability:
All of the system components ensure smooth, continuous operation
24/7 and 365 days per year.**

- Function and pressure tests of all mechanical and electrical components ensure quality control
- EMC filter protects the main power supply and the connected components against harmonic waves produced by the chiller
- Line reactor for the protection of the chiller against voltage peaks
- The line reactor as well as the EMC filter are installed per each compressor to ensure maximum operational reliability
- Soft start of the compressor with an inrush current of < 5 amps.
- The compressors start up one by one, to ensure that the main power supply is stable
- System components are standardized and can be acquired easily, which facilitates replacement of parts and ensures reliability
- Quality management from development to start-up, through certification to ISO 9001 and ISO 14001



Climate. Customized. You have the challenge, we have the solution.



- Location
- Room planning
- Local climate
- Environmental protection
- Noise protection
- Generation of heat
- Peace of mind
- Integration and connectivity
- In-house engineering
- In-house software development

STULZ customers always receive solutions that are customized and are perfectly configured for the applications in question.

From standard units to fully tailor-made customer solutions – the ability to offer such a wide range to customers is the embodiment of our philosophy, “Climate. Customized.”. Our aim is to realize our customers' wishes in the ideal way and to create sustainable, and perfectly adapted air conditioning solutions that are equally powerful, reliable and efficient.



Climate Customized #1 Standard units

For its standard units, STULZ offers a huge selection of accessories and options to permit a high level of flexibility and individualization.



Climate Customized #2 Standard units with special options

In addition to the standard units, STULZ can adapt the standard units to produce highly bespoke designs, to meet customer-specific needs.

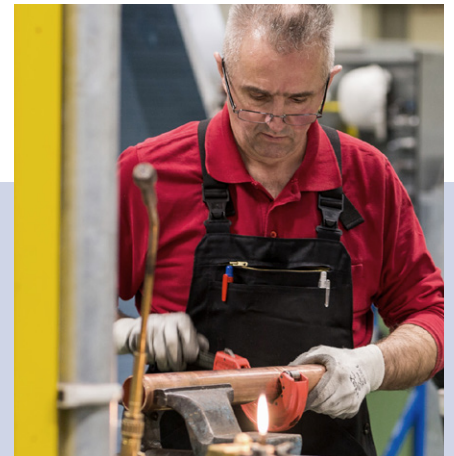

Climate Customized #3 Tailor-made air conditioning solutions

STULZ has the solution! In collaboration with the customer and tailored to suit requirements, we plan, implement and continuously look after the perfect air conditioning solution. This allows the development of individual air conditioning solutions with performance features which all match one another perfectly from the outset.

Nomenclature

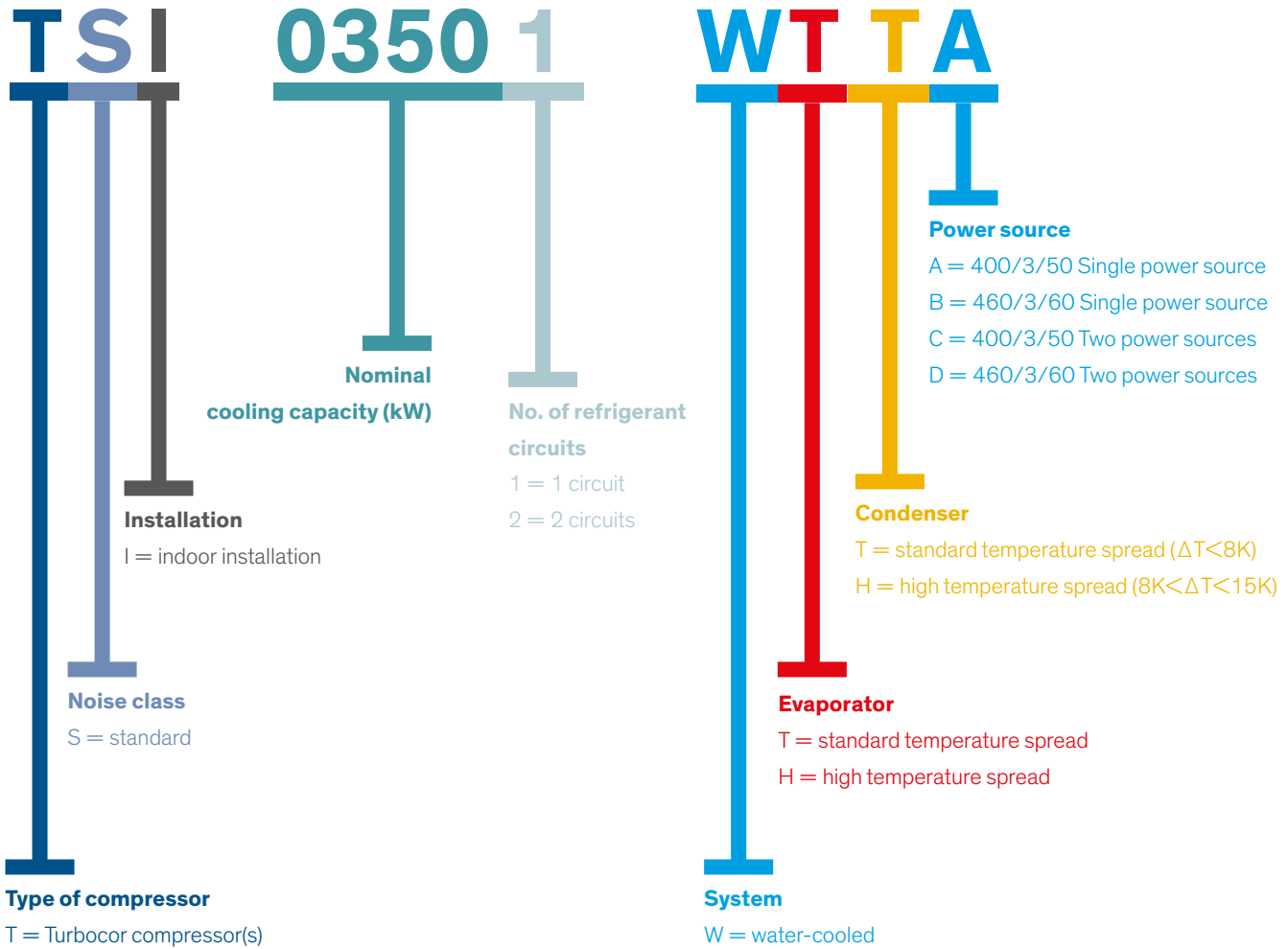

Summary of dimensions

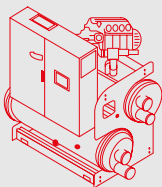

Size 1

L x W x H (mm)
2,089 x 1,185 x 1,955
1 refrigerant circuit
1 compressor

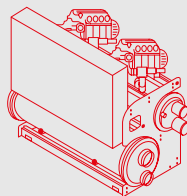

Size 2

L x W x H (mm)
2,733 x 1,330 x 2,060
1 refrigerant circuit
2 compressors

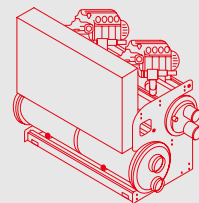

Size 3

L x W x H (mm)
2,733 x 1,330 x 2,060
2 refrigerant circuits
2 compressors

Technical data

Performance data TSI - WTTA

Model		03501	07001	07002	10502	14002
Operating point 18°C/12°C ⁽¹⁾						
Cooling capacity	kW	378	769	769	1,135	1,513
Total power consumption	kW	64	142	142	192	256
EER	kW/kW	5.9	5.4	5.4	5.9	5.9
Noise						
Noise level ⁽²⁾	dB(A)	60.4	63.3	63.3	64.9	66.1
Dimensions						
Width	mm	2089	2,733	2,733	3,793	3,832
Depth	mm	1,185	1,330	1,330	1,490	1,630
Height	mm	1,955	2,060	2,060	2,105	2,390
Transportation weight	kg	2,017	3,117	3,117	4,540	5,968
Operating weight	kg	2,227	3,442	3,442	5,250	6,837

¹⁾ Chilled water inlet/-outlet 18/12 °C, Cooling water inlet/-outlet 30/35 °C (30% Ethylene glycol)

²⁾ Noise level from 10 m distance

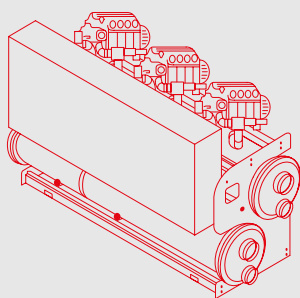

Size 4

L x W x H (mm)

3,793 x 1,490 x 2,105

2 refrigerant circuits

3 compressors

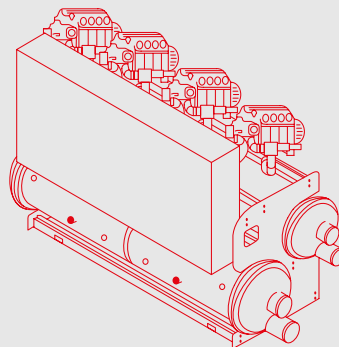

Size 5

L x W x H (mm)

3,832 x 1,630 x 2,390

2 refrigerant circuits

4 compressors

STULZ Company Headquarters

STULZ GmbH

Holsteiner Chaussee 283
22457 Hamburg
Tel. +49 40 5585-0
products@stulz.de

STULZ Subsidiaries

GERMANY
AUSTRALIA
AUSTRIA
BELGIUM
BRAZIL
CHINA
FRANCE
INDIA
INDONESIA
ITALY
MEXICO
NETHERLANDS
NEW ZEALAND
POLAND
SINGAPORE
SOUTH AFRICA
SPAIN
SWEDEN
UNITED KINGDOM
USA

STULZ Australia Pty. Ltd.

34 Bearing Road
Seven Hills NSW 2147
Tel. +61 (2) 96744700
sales@stulz.com.au

STULZ Austria GmbH

Industriezentrum NÖ – SÜD,
Straße 15, Objekt 77, Stg. 4, Top 7
2355 Wiener Neudorf
Tel. +43 1 615 99 81-0
info@stulz.at

STULZ Belgium BVBA

Tervurenlaan 34
1040 Brussels
Tel. +32(470)292020
info@stulz.be

STULZ Brasil

Ar Condicionado Ltda.
Rua Cancioneiro de Évora, 140
Bairro - Santo Amaro São
Paulo-SP, CEP 04708-010
Tel. +55 11 4163 4989
comercial@stulzbrasil.com.br

STULZ Air Technology and Services Shanghai Co., Ltd.

Room 406, Building 5
457 North Shanxi Road
Shanghai 200040
Tel: + 86 21 3360 7101
info@stulz.cn

STULZ France S. A. R. L.

107, Chemin de Ronde
78290 Croissy-sur-Seine
Tel. +33(1)34 80 47 70
info@stulz.fr

STULZ-CHSPL (India) Pvt. Ltd.

006, Jagruti Industrial Estate
Mogul Lane, Mahim
Mumbai - 400016
Tel. +91 (22) 56 66 94 46
info@stulz.in

PT STULZ Air Technology Indonesia

Kebayoran Square blok KQ unit A-01
Jalan Boulevard Bintaro Jaya,
Bintaro Sektor 7,
Tangerang Selatan 15229
Tel. +62 21 2221 3982
info@stulz.id

STULZ S.p.A.

Via Torricelli, 3
37067 Valeggio sul Mincio (VR)
Tel. +39(045)633 1600
info@stulz.it

STULZ México S.A. de C.V.

Avda. Santa Fe No. 170
Oficina 2-2-08, German Centre
Delegación Alvaro Obregon
MX- 01210 México
Distrito Federal
Tel. +52(55)52928596
ventas@stulz.com.mx

STULZ GROEP B. V.

Postbus 75
180 AB Amstelveen
Tel. +31(20)5451 111
stulz@stulz.nl

STULZ New Zealand Ltd.

Unit O, 20 Cain Road
Penrose, Auckland 1061
Tel. +64(9)360 32 32
sales@stulz.co.nz

STULZ Polska SP. Z O.O.

Budynek Mistral.
Al. Jerozolimskie 162
02 – 342 Warszawa
Tel. +48(22)883 30 80
info@stulz.pl

STULZ Singapore Pte Ltd.

1 Harvey Road
#04-00 Tan Heng Lee Building
Singapore 369610
Tel. +65 6749 2738
sales@stulz.sg

STULZ South Africa Pty. Ltd.

Unit 3, Jan Smuts Business Park
Jet Park, Boksburg
Gauteng, South Africa
Tel. +27(0)11 397 2363
aftersales@stulz.co.za

STULZ España S.A.

Calle Carabaña, 25C
28925 Alcorcón (Madrid)
Tel. +34(91)517 83 20
info@stulz.es

STULZ Sverige AB

Västertorpsvägen 135
129 44 Hägersten
Stockholm, Sweden
Tel. +46 8 12157550
info@stulzverige.se

STULZ U. K. Ltd.

First Quarter,
Blenheim Rd. Epsom
Surrey KT 19 9 QN
Tel. +44(1372)74 96 66
sales@stulz.co.uk

STULZ AIR TECHNOLOGY SYSTEMS (STULZ USA) , INC.

1572 Tilco Drive
Frederick, MD 21704
Tel. +1(301)620 20 33
info@stulz-ats.com

Technical data subject to change; errors and omissions excepted. 1100593 V1.2 11-18 en · © STULZ GmbH, Hamburg

Close to you around the world

With specialist, competent partners in ten German branches and in subsidiaries and exclusive sales and service agents around the world.

Our ten production sites are situated in Europe, North America and Asia.

For further information, please visit our website at www.stulz.com

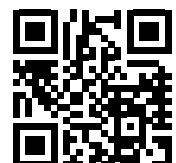

You can find out more
on our product page.